

# TRK-ZON<sup>®</sup>

## AUTONOMOUS LORA ZONE BEACON



## USE CASES



### INVENTORY AND STOCK MANAGEMENT

Invents your equipment by simply installing a zone beacon in storage locations. INEO-SENSE TRK-Tracer tags identify the beacon and trace the information back to the network.



### CHECK IN / CHECK OUT

Identifies inbound and outbound assets at your guard posts, on the fly and in real time, without having to open your vehicles.



### TRACKING PRODUCTION FLOWS

Tracks the progress of production steps in real time by judiciously positioning the zone beacon at each stage.

## PRODUCT HIGHLIGHTS

### AUTONOMOUS AND WIRELESS

TRK-Zon can be installed anywhere without worrying about wiring, indoor and outdoor. Its magnet installation is simple, fast and automatic.

### LONG RANGE UP TO 300M

Defines areas ranging from a few m<sup>2</sup> to about 100 m<sup>2</sup>.

### SIMPLE IDENTIFICATION BY LED

Identifies your zone tags with ease when setting up.

### BATTERY LIFE OPTIMIZATION > 4 ANS

### TIME-STAMPING AND DATALOGGING OF EVENTS (+8000)

### OPTIONS AVAILABLE

- Activation by motion sensor,
- Power on power outlet,
- Customization on request:
  - Case color and labeling,
  - Specific business features.



### CLOVER-NET TECHNOLOGY

Real-time two-way communication protocol to facilitate the installation and setting of sensors, collection of time-stamped data, automatic inventories, OTA updates...

# SPECIFICATIONS

## Mechanical specificities

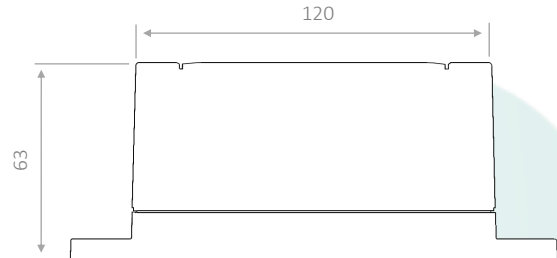
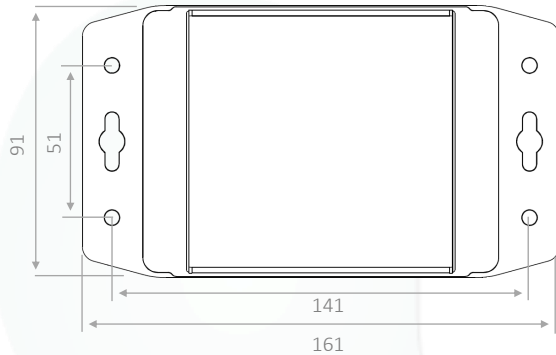

## Fastening system

Screw

Magnet (in option supply)

Glue

## Physical Characteristics

Battery	Lithium 34Ah replaceable
Material	ABS PC V0 UL94
Weight	300 g
IP Index	IP66
IK index	IK07
Operating temperature	-20°C to 70°C
Storage Temperature	-40°C to 80°C
Humidity	< 95% without condensation



**CAUTION: THIS PRODUCT USE LITHIUM BATTERY.**

FOR YOUR SAFETY, PLEASE CHECK OUR WEBSITE

## Data transmitted

Motion detection

Battery and temperature level

Setting by Downlink

## Certifications

CE, EN 300-220

## Communication

LoRaWAN	Class A
	EU868, 915US, AU915, AS923
	Private Mode and Public mode
	OTAA and A BP
	Transmitting Power 14dBm (EU) 20dBm max
	Compatible operator: Objenious, Orange and network core, Actility, Orbiwise, TTN, Lorient ...
CloverNet	Broadcast, multicast, point-to-point

## INEO-SENSE

125 Rue de L'hostellerie,  
Immeuble ELLIPSIS, Niv 4 Porte 12  
30 900 Nîmes — France

Phone : +33 466 276 495  
Web : [www.ineo-sense.com](http://www.ineo-sense.com)  
[contact@ineo-sense.com](mailto:contact@ineo-sense.com)