

TRK-TRACER[®]



LOCATE, IDENTIFY AND INVENTORY YOUR EQUIPMENT



USE CASES



PRODUCTION FLOWS TRACKING

Tracks the progress of production steps in real time. Identifies priorities. Finds the boxes out of process.



STOCK MANAGEMENT

Analyzes transport times and usage rates. Inventories packaging on each site for better operation.



ANALYSIS OF THE USAGE RATE

Inventories and locates the big tools or construction equipment. Detects exits from the operating area. Ensures that the construction equipment is properly loaded. Reduces thefts.

PRODUCT HIGHLIGHTS

LOCATION BY ZONE

PICK-TO-LIGHT (BICOLOR LED)

To find and identify your assets at a glance.

TIME-STAMPING AND DATALOGGING of events (+3000)

USAGE RATE MONITORING thanks to the motion sensor.

RADIO SNIFFING FOR AN OUT-OF-ZONE RESEARCH

OPTIMIZATION OF THE BATTERY LIFE > 7 YEARS

AGILE SETTINGS

TRK-Tracer once deployed, remains configurable to adjust your use case to your needs.

AVAILABLE OPTIONS

- Buzzer-type audible alarm,
- Customization on request:
 - Specific business functions
 - Case color and labeling,



TECHNOLOGIE CLOVER-NET

Real-time two-way communication protocol to facilitate the installation and setting of sensors, collection of time stamped data, automatic inventories, OTA updates...

SPECIFICATIONS

Mechanical specificities

Without flanges

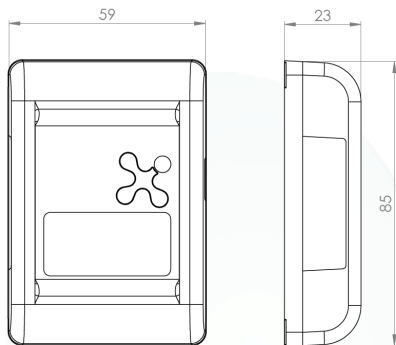

With flanges

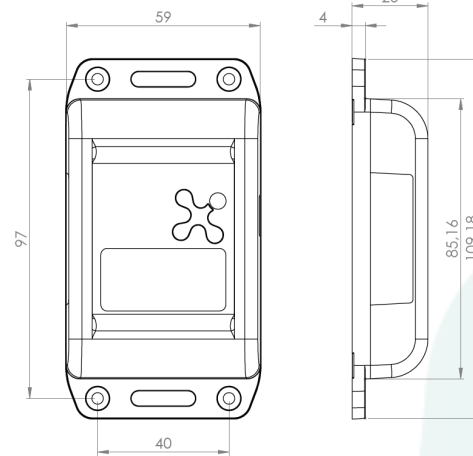

Fastening system

Screw

Magnet (optional)

Glue

Certifications

CE, EN 300-220

Physical characteristics

Battery	Lithium 3.6Ah replaceable
Material	ABS PC V0 UL94
Weight	94g
IP index	IP54 or IP66
IK index	IK07 or IK08 (optional)
Operating temperature	-20°C to 70°C
Storage temperature	-40°C to 80°C
Humidity	< 95% without condensation



CAUTION: THIS PRODUCT USES LITHIUM BATTERY.
FOR YOUR SAFETY, PLEASE CHECK OUR WEBSITE.

Communication

LoRaWAN	Classe A
	EU868, 915US, AU915, AS923
	Private and public networks
	OTAA and ABP
	Power transmission : 14dBm (EU) to 20dBm max
	Operator compatible : Objenious, Orange...
	Core network providers : Actility, Orbiwise, TTN, Loriot ...
Sigfox (option)	RC1/RC2/RC4
CloverNet	Broadcast, multicast, point-to-point

Battery life

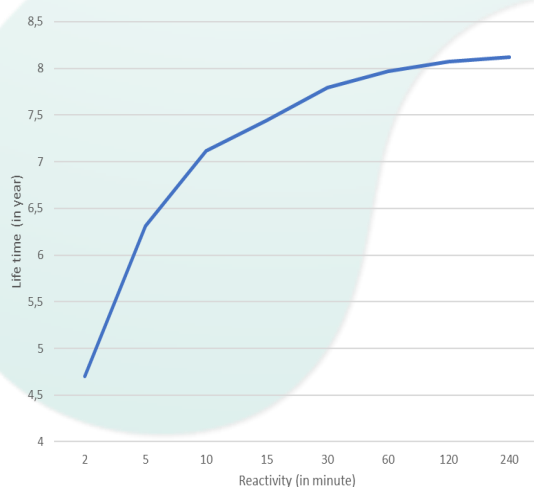

Use case

10-day cycle, 15-zone changes
Activity : 24h/24h
Presence frame every 24 hours
Alarm on zone change
Pick-To-Light at every step for 30s

Data transmitted

Change of zone events
Track record of crossing the zones
Motion detection
Usage rate monitoring
Battery and temperature level
Product configuration by Downlink

INEO-SENSE

125 Rue de L'hostellerie,
Immeuble ELLIPSIS, Niv 4 Porte 12
30 900 Nîmes — France

Phone : +33 466 276 495
Web : www.ineo-sense.com
contact@ineo-sense.com

© 2020 Ineo-Sense. All rights reserved. Clover-Net, Clover-Sense, TRK-Tracer, are trademarks of Ineo-Sense company. All other brands mentioned are the property of their respective holders. This is non-contractual document, and may be modified without notice.